

Daisy Pod

Breakout Board for the Daisy Seed

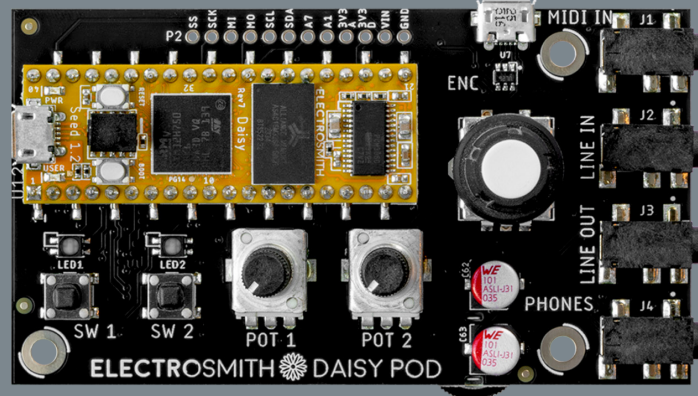

Features:

- Daisy Seed breakout board for line level audio applications
- USB Powered (microUSB port via Daisy Seed)
- Peripheral controls:
 - 2 plastic potentiometers, 10KB
 - 1 clicked encoder, D shaft
 - 2 tactile switches
 - 2 RGB LEDs
 - 1 rotary headphone volume control
- Board connectors
 - 3.5mm jacks for stereo audio I/O
 - 3.5mm TRS MIDI input jack
 - 3.5mm stereo headphone jack
 - 1 onboard microUSB port
 - Extra pinouts for sensors and OLED screens
 - Extra pinouts for power and ground
- Open source hardware (MIT license)
- Comprehensive API including DSP building blocks, hardware functionality, and more.

- Daisy Seed onboard:
 - 96kHz / 24-bit audio hardware
 - 64MB of SDRAM for up to 10 minute long audio buffers
 - ARM Cortex-M7 MCU, running at 480MHz
 - 31 total GPIO pins with configurable functionality
 - 12-bit Digital to Analog Converters (x2)
 - SD card interfaces
 - PWM outputs
 - Serial Protocols for connecting external sensors and devices (SPI, UART, I2s, I2C)
 - Dedicated VIN pin for power
 - Micro USB port, and additional USB pins for full OTG-support as host and device

Applications:

- Line level audio devices
- DSP prototyping
- Educational purposes



Description

Start programming the Daisy without breadboarding! The Pod is a USB powered breakout board for the Daisy. With stereo line level I/O, MIDI input and headphone output with a dedicated volume control, this is the feature-packed, small-form breakout to get started with for development.

Includes x1 Daisy Seed

Ordering Information

To order the Daisy Pod for volume purchases, tax exempt purchases, and the like, refer to table 1. For all other orders, see the product web page.

Order Code	Description	Target Board	Product Link
ES_Daisy_Pod	Daisy Breakout Board	Daisy Seed	link

Development Environment

System Requirements

- Windows® OS, Linux® 64-bit, or macOS®
- microUSB cable, Type-A
- 3.5mm headphones and/or 3.5mm audio jack to speakers

Toolchains & Recommended Development Software

- [Daisy Toolchain](#)
- [VS Code](#)

For additional reference documentation and both hardware and software examples for the Daisy Seed, head to the [Daisy support site](#).

Tutorials

Get started with your Daisy Pod by following our guided programming tutorials.

- [C++](#)
- [Arduino](#)
- [Oopsy](#)



Pod Pinout

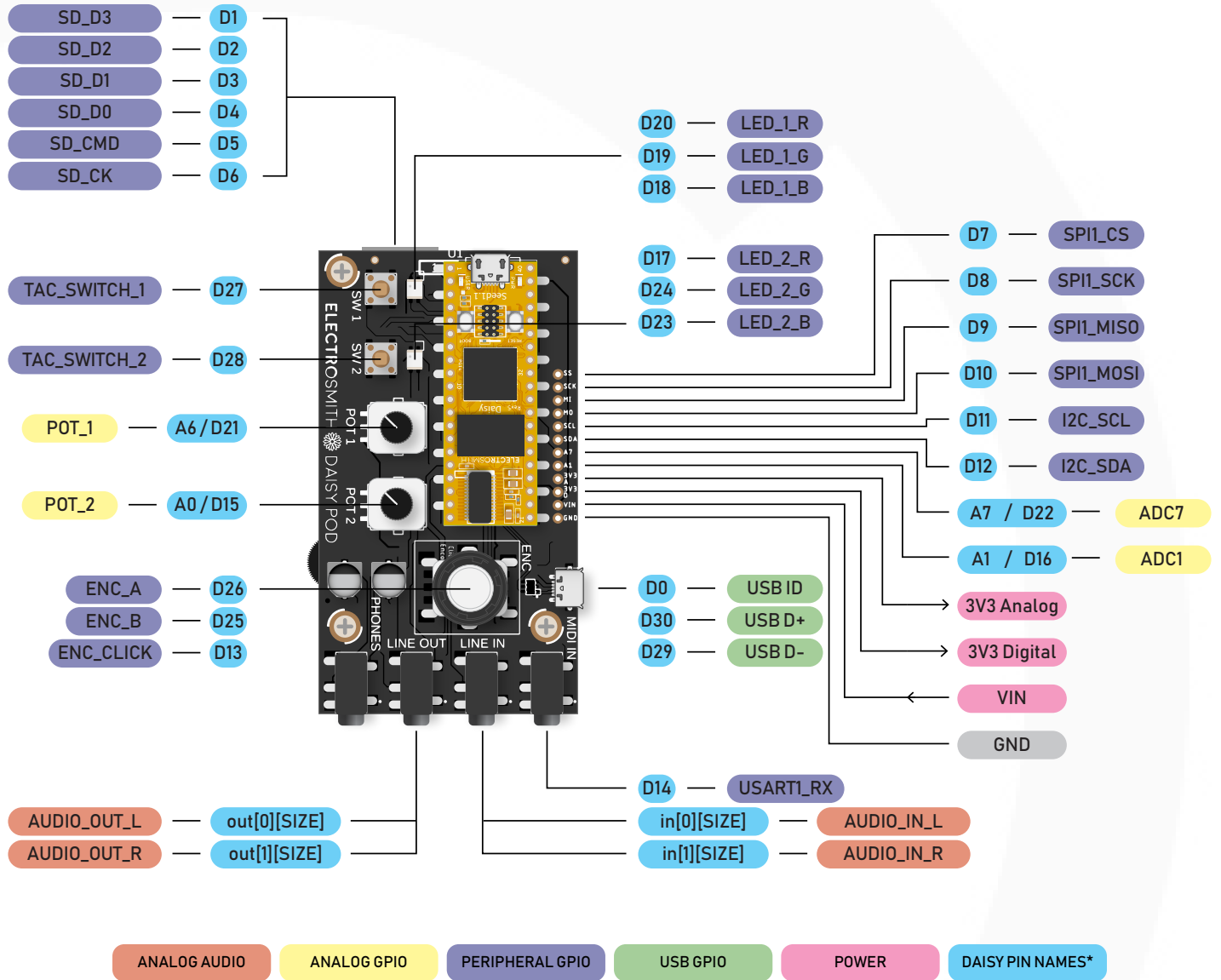

* "D" for Digital GPIO or "A" for Analog I/O, depending on use case.



Changelog

RELEASE	DATE	DESCRIPTION
v1.0	MAR/13/2025	<ul style="list-style-type: none">Initial release
v1.1	MAY/14/2026	<ul style="list-style-type: none">updated assets to match Pod Rev7



Colophon

Copyright (c) 2021 Electrosmith

Permission is hereby granted, free of charge, to any person obtaining a copy of this software and associated documentation files (the "Software"), to deal in the Software without restriction, including without limitation the rights to use, copy, modify, merge, publish, distribute, sublicense, and/or sell copies of the Software, and to permit persons to whom the Software is furnished to do so, subject to the following conditions:

The above copyright notice and this permission notice shall be included in all copies or substantial portions of the Software.

THE SOFTWARE IS PROVIDED "AS IS", WITHOUT WARRANTY OF ANY KIND, EXPRESS OR IMPLIED, INCLUDING BUT NOT LIMITED TO THE WARRANTIES OF MERCHANTABILITY, FITNESS FOR A PARTICULAR PURPOSE AND NONINFRINGEMENT. IN NO EVENT SHALL THE AUTHORS OR COPYRIGHT HOLDERS BE LIABLE FOR ANY CLAIM, DAMAGES OR OTHER LIABILITY, WHETHER IN AN ACTION OF CONTRACT, TORT OR OTHERWISE, ARISING FROM, OUT OF OR IN CONNECTION WITH THE SOFTWARE OR THE USE OR OTHER DEALINGS IN THE SOFTWARE.
