

Daisy Patch Submodule

Eurorack Module DSP Engine

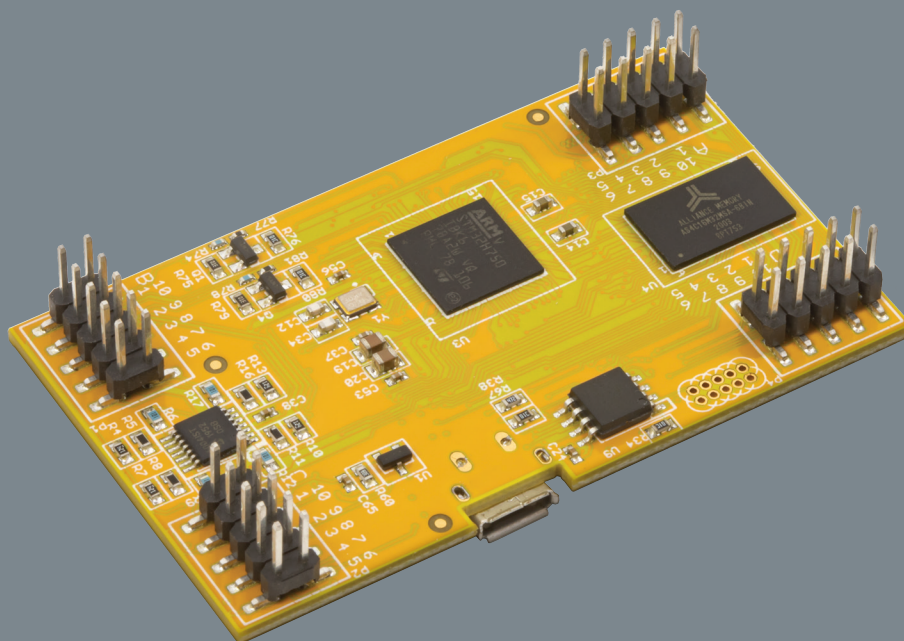

Features:

- Eurorack Module DSP Engine Submodule
- 96kHz / 24-bit audio hardware
- 64MB of SDRAM for up to 10 minute long audio buffers
- Industry Leading Noise Performance
- x12 - Bipolar CV / Potentiometer Inputs (16-Bit)
- x2 Gate Inputs / x2 Gate Outputs / x2 DAC Outputs (12-Bit)
- USB Firmware Flashing via Open Source Web Interface
- USB MIDI Capable
- Stereo Eurorack Level Audio Input / Outputs
- SD Card Interface

Applications:

- Effects Processors (Reverb, Granular, Delay)
- Samplers (Sample Player, Looper, Glitch)
- Sound Generators (VCO, Physical Modelling, Drums)
- Sequencers (Pitch Sequencer, MIDI Sequencer, Gate Pattern Generator)
- CV Generator (Random Voltage, LFO, Envelope, MIDI to CV/CV to MIDI)

Description:

The Daisy Patch Submodule is a complete Eurorack module DSP engine. All modular specific circuitry, such as Audio IO, CV/Gate IO, etc., is installed onboard. Simply design your carrier board, and let the Patch Submodule do the rest!

It can be programmed in a number of languages/environments including C++, Max/MSP Gen~, Pure Data, and Arduino. These languages can be coupled with our open source DSP library, [DaisySP](#), for a full fledged music synthesis programming environment. In addition, there is a multitude of example programs and template code for accomplishing standard tasks such as audio pass through, reading CVs and potentiometers, MIDI, and more.

The slim form factor can be installed on modules as small as 8HP, and thanks to the header landing pattern, can easily fit between tactile controls such as jacks, potentiometers, and switches. The submodule mates to a Eurorack carrier board using standard (2.54mm pitch 2x5) [headers](#).

Take your Eurorack designs to the next level with the Daisy Patch Submodule.



Colophon

Copyright (c) 2021 Electrosmith

Permission is hereby granted, free of charge, to any person obtaining a copy of this software and associated documentation files (the "Software"), to deal in the Software without restriction, including without limitation the rights to use, copy, modify, merge, publish, distribute, sublicense, and/or sell copies of the Software, and to permit persons to whom the Software is furnished to do so, subject to the following conditions:

The above copyright notice and this permission notice shall be included in all copies or substantial portions of the Software.

THE SOFTWARE IS PROVIDED "AS IS", WITHOUT WARRANTY OF ANY KIND, EXPRESS OR IMPLIED, INCLUDING BUT NOT LIMITED TO THE WARRANTIES OF MERCHANTABILITY, FITNESS FOR A PARTICULAR PURPOSE AND NONINFRINGEMENT. IN NO EVENT SHALL THE AUTHORS OR COPYRIGHT HOLDERS BE LIABLE FOR ANY CLAIM, DAMAGES OR OTHER LIABILITY, WHETHER IN AN ACTION OF CONTRACT, TORT OR OTHERWISE, ARISING FROM, OUT OF OR IN CONNECTION WITH THE SOFTWARE OR THE USE OR OTHER DEALINGS IN THE SOFTWARE.



This equipment has been tested and found to comply with the limits for a Class A digital device, pursuant to Part 15 of the FCC Rules. These limits are designed to provide reasonable protection against harmful interference when the equipment is operated in a commercial environment. This equipment generates, uses, and can radiate radio frequency energy and, if not installed and used in accordance with the instruction manual, may cause harmful interference to radio communications. Operation of this equipment in a residential area is likely to cause harmful interference, in which case the user will be required to correct the interference at his own expense. This device complies with Part 15 of the FCC Rules. Operation is subject to the following two conditions: this device may not cause harmful interference, and this device must accept any interference received, including interference that may cause undesired operation.

WARNING

The connection of a non-shielded equipment interface cable to this equipment will invalidate the FCC Certification of this device and may cause interference levels which exceed the limits established by the FCC for this equipment. It is the responsibility of the user to obtain and use a shielded equipment interface cable with this device. If this equipment has more than one interface connector, do not leave cables connected to unused interfaces. Changes or modifications not expressly approved by the manufacturer could void the user's authority to operate the equipment.

WARNING

This is a Class A product. In a domestic environment this product may cause radio interference, in which case the user may be required to take adequate measures.

Disclaimer: Electrosmith products should not be used in medical or life saving devices, or any uses requiring fail-safe performance. Electrosmith reserves the right to change, add, or remove any information and assets included in the Daisy Seed datasheet at any time without prior notice.



Table of Contents

Pinout	1
Pinout Tables	
• Absolute Maximum Ratings Table 1	2
• Pin Functions Table 2	3
• Electrical Characteristics Table 3	4
Performance	
• Noise Floor	5
• SNR : 1kHz Reference Sine Wave	5
Typical Applications	
• 1.1 Stereo Audio Input	6
• 1.2 Potentiometers	6
• 1.3 CV Input	6
• 1.4 Gate Input	7
• 1.5 Tactile Switch	7
• 1.6 Toggle Switch	7
• 1.7 Micro SD	8
• 1.8 Stereo Audio Output	8
• 1.9 CV Output	8
• 1.10 Gate Output	9
• 1.11 Power	9
• 1.12 LED	9
• 1.13 On-Off-On Toggle Switch	10
Technical Drawing	11
Landing Pattern	12
Why The Daisy Patch Submodule	13
Changelog	14



Pinout

See Tables 1, 2, and 3 for pin descriptions

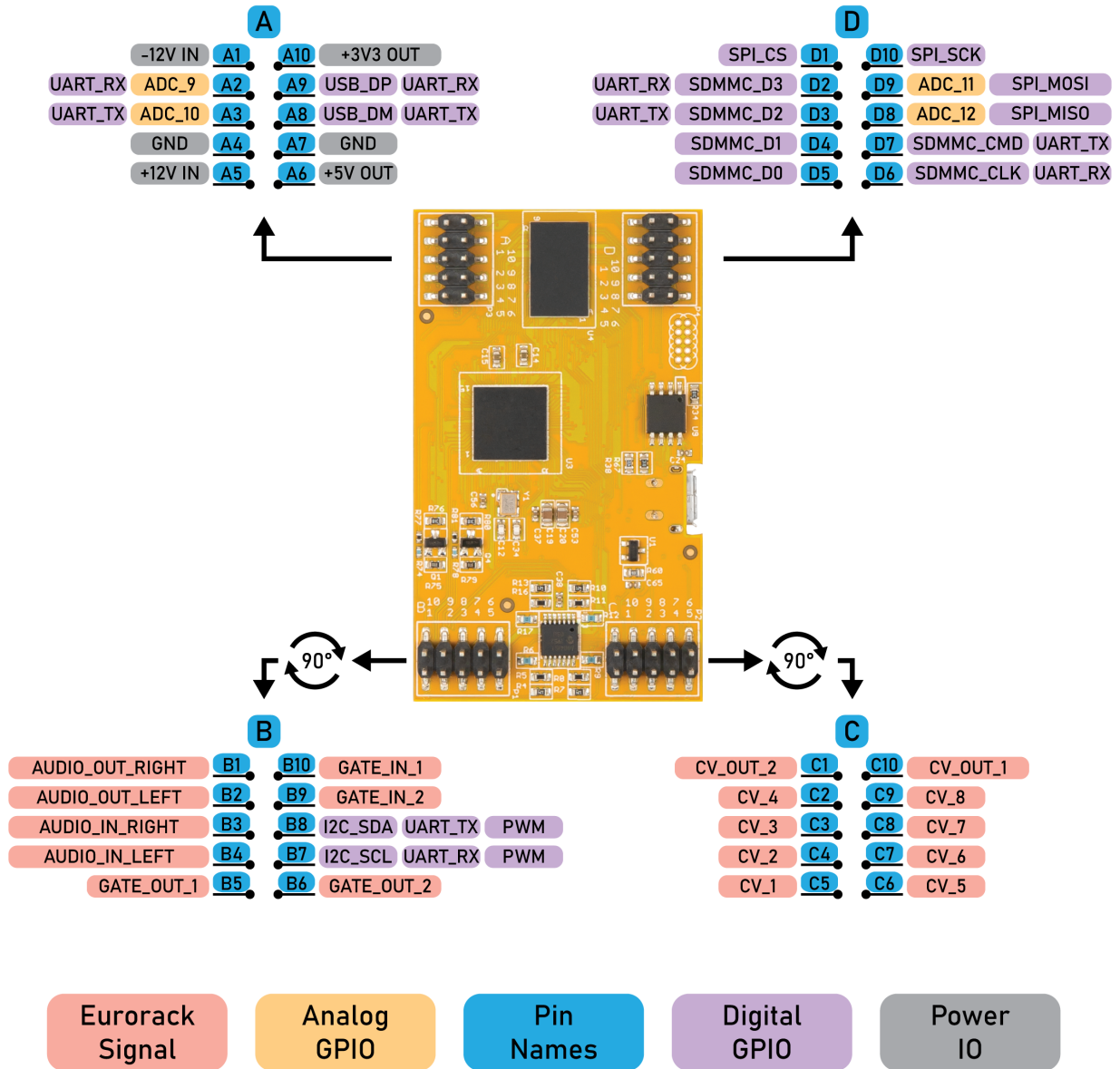

PIN TYPE	Min	Max	Unit
Positive Power Input	6	17	V
Negative Power Input	-6	-17	V
Ground	0	0	V
5V Output		800	mA
3V3 Output		500*	mA
GPIO	-0.3	6**	V
Audio IO	Negative Power In	Positive Power In	V
Gate Input	Negative Power In	Positive Power In	V
Gate Output	0	5	V
CV Input	Negative Power In	Positive Power In	V
CV Output	0	5	V

* Maximum output current is firmware dependent.

** To sustain a voltage higher than 4V the internal pull-up/pull-down resistors must be disabled.

Powering the Daisy Patch SM from both the VIN and USB: The Daisy Seed2 DFM re-quires VIN for full operation, but will not cause damage if you connect USB while it's powered. It is also possible to partially power the Daisy Seed2 DFM via USB for firmware updates, etc. with-out VIN applied. However, while powered this way, the Audio codec will not function properly.

PIN NAME	PRIMARY NAME	STM32 Pin	DETAIL	ALT. FUNCTION
A1	-12V	N/A	Negative Power Input	N/A
A2	ADC_9	PA1	GPIO	UART4_RX
A3	ADC_10	PA0	GPIO	UART4_TX
A4	GND	N/A	Ground	N/A
A5	12V	N/A	Positive Power input	N/A
A6	5V	N/A	Positive Power output	N/A
A7	GND	N/A	Power	N/A
A8	USB_DM	PB14	GPIO	USART1_TX
A9	USB_DP	PB15	GPIO	USART1_RX
A10	3V3	N/A	Power output	N/A
B1	AUDIO_OUT_RIGHT	N/A	DC Coupled Audio	N/A
B2	AUDIO_OUT_LEFT	N/A	DC Coupled Audio	N/A
B3	AUDIO_IN_RIGHT	N/A	AC Coupled Audio	N/A
B4	AUDIO_IN_LEFT	N/A	AC Coupled Audio	N/A
B5	GATE_OUT_1	PC14	Output Only	N/A
B6	GATE_OUT_2	PC13	Output Only	N/A
B7	I2C1_SCL	PB8	GPIO	UART4_RX, PWM (TIM4_CH3)
B8	I2C1_SDA	PB9	GPIO	UART4_TX, PWM (TIM4_CH4)
B9	GATE_IN_2	PG14	Input Only	N/A
B10	GATE_IN_1	PG13	Input Only	N/A
C1	CV_OUT_2	PA5	Output Only	N/A
C2	CV_4	PA7	Input Only	N/A
C3	CV_3	PA2	Input Only	N/A
C4	CV_2	PA6	Input Only	N/A
C5	CV_1	PA3	Input Only	N/A
C6	CV_5	PB1	Input Only	N/A
C7	CV_6	PC4	Input Only	N/A
C8	CV_7	PC0	Input Only	N/A
C9	CV_8	PC1	Input Only	N/A
C10	CV_OUT_1	PA4	Output Only	N/A
D1	SPI2_CS	PB4	GPIO	N/A
D2	SDMMC1_D3	PC11	GPIO	USART3_RX*
D3	SDMMC1_D2	PC10	GPIO	USART3_TX*
D4	SDMMC1_D1	PC9	GPIO	N/A
D5	SDMMC1_D0	PC8	GPIO	N/A
D6	SDMMC1_CLK	PC12	GPIO	UART5_TX*
D7	SDMMC1_CMD	PD2	GPIO	UART5_RX*
D8	ADC_12	PC2	GPIO	SPI2_MISO
D9	ADC_11	PC3	GPIO	SPI2_MOSI
D10	SPI2_SCK	PD3	GPIO	N/A

* 47K pullups are connected to this pin. This may have an effect on the behavior when used as UART

* The min/max rating in this table represents the expected operating range for the device. Signals outside of this range will not necessarily damage the Daisy Patch Submodule. See [Table 1](#) for Absolute min/max ratings.

PIN NAME	PRIMARY NAME	Min	Max	Typical
A1	-12V			-12V (input only)
A2	ADC_9	0V	3V3	0 to 3V3
A3	ADC_10	0V	3V3	0 to 3V3
A4	GND			GND
A5	12V			12V (input only)
A6	5V			5V (output only)
A7	GND			GND
A8	USB_DM	0V	3V3	0 to 3V3
A9	USB_DP	0V	3V3	0 to 3V3
A10	3V3			3V3 (output only)
B1	AUDIO_OUT_RIGHT	-12V	12V	-5V to 5V
B2	AUDIO_OUT_LEFT	-12V	12V	-5V to 5V
B3	AUDIO_IN_RIGHT	-12V	12V	-5V to 5V
B4	AUDIO_IN_LEFT	-12V	12V	-5V to 5V
B5	GATE_OUT_1	0V	5V	0 to 5V
B6	GATE_OUT_2	0V	5V	0 to 5V
B7	I2C_SCL	0V	3V3	0 to 3V3
B8	I2C_SDA	0V	3V3	0 to 3V3
B9	GATE_IN_2	Negative Power In	Positive Power In	0 to 5V
B10	GATE_IN_1	Negative Power In	Positive Power In	0 to 5V
C1	CV_OUT_2	0V	5V	0 to 5V
C2	CV_4	-5V	5V	-5V to 5V
C3	CV_3	-5V	5V	-5V to 5V
C4	CV_2	-5V	5V	-5V to 5V
C5	CV_1	-5V	5V	-5V to 5V
C6	CV_5	-5V	5V	-5V to 5V
C7	CV_6	-5V	5V	-5V to 5V
C8	CV_7	-5V	5V	-5V to 5V
C9	CV_8	-5V	5V	-5V to 5V
C10	CV_OUT_1	0V	5V	0 to 5V
D1	SPI_CS	0	3V3	0 to 3V3
D2	SDMMC_D3	0	3V3	0 to 3V3
D3	SDMMC_D2	0	3V3	0 to 3V3
D4	SDMMC_D1	0	3V3	0 to 3V3
D5	SDMMC_D0	0	3V3	0 to 3V3
D6	SDMMC_CLK	0	3V3	0 to 3V3
D7	SDMMC_CMD	0	3V3	0 to 3V3
D8	ADC_12	0	3V3	0 to 3V3
D9	ADC_11	0	3V3	0 to 3V3
D10	SPI_SCK	0	3V3	0 to 3V3



Performance

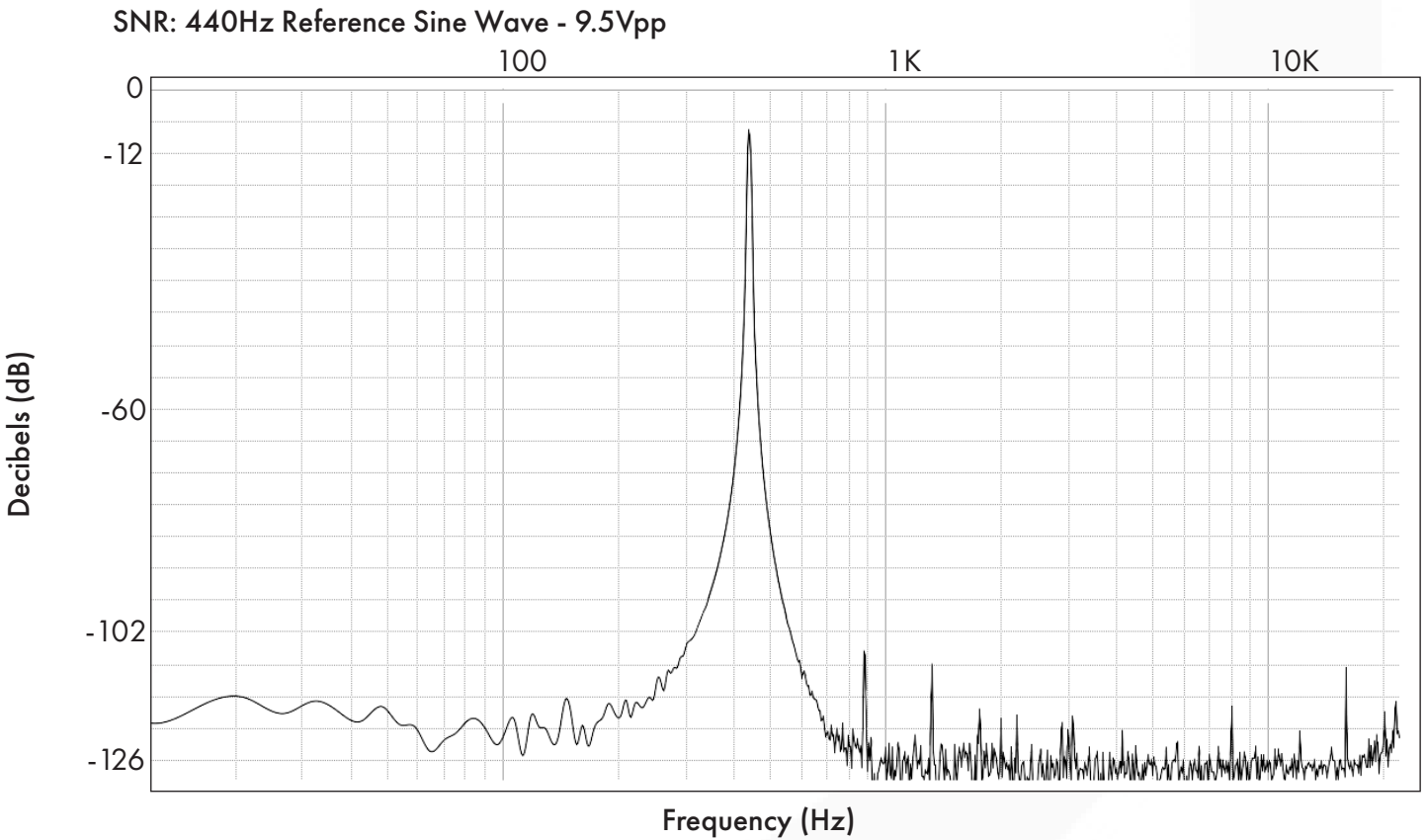
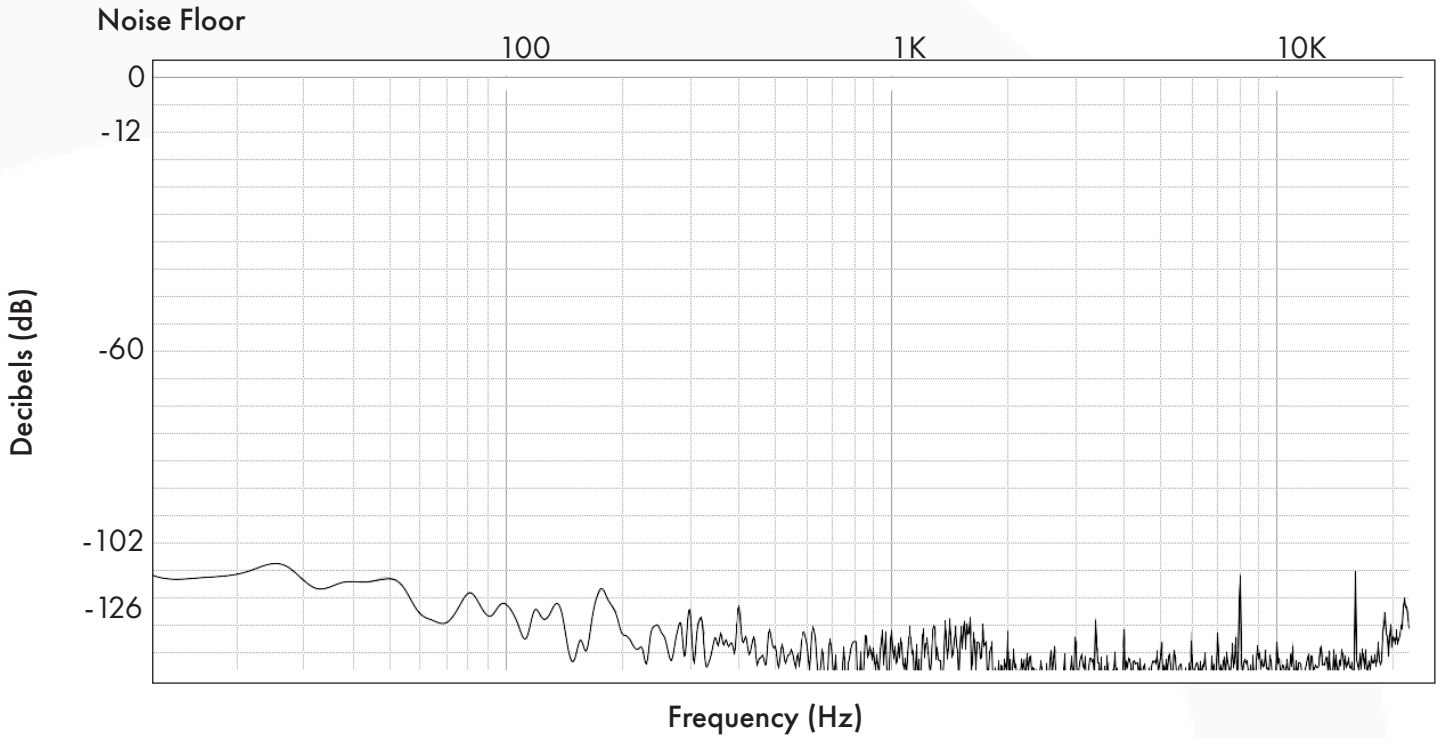



Typical Applications

For electrical characteristics, see Table 2

Figure 1.1 - Stereo Audio Input application example

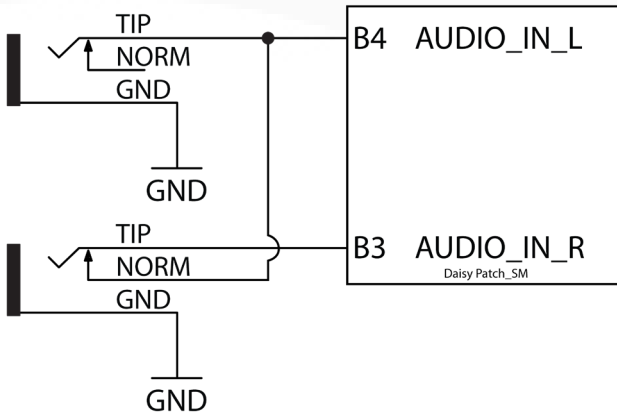

Jack 1 normals to Jack 2 to maintain stereo inputs when nothing is connected to channel 2.

Input Impedance: 100K

Example Parts:

[Thonkiconn 3.5mm Mono Eurorack Jack](#)

MPN: WQP-WQP518MA

Figure 1.2 - Potentiometers application example

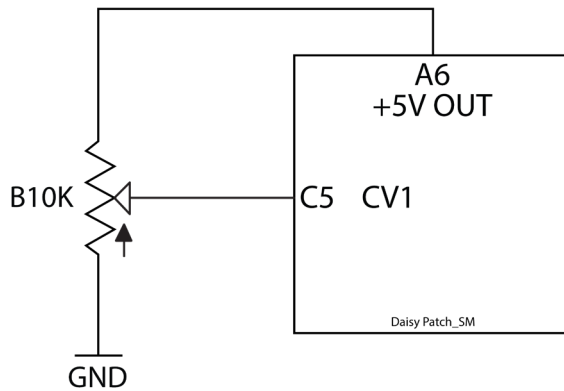

Available Pins:

CV_1 to CV_8

ADC_9 to ADC_12*

Example Parts:

[Alpha 9mm Linear 10K D Shaft](#)

MPN: RD901F-40-15F-B10K-00D70

* When using ADC_9 to ADC_12, use +3V3 OUT (A10) instead of +5V OUT (A6)

Figure 1.3 - CV Input application example

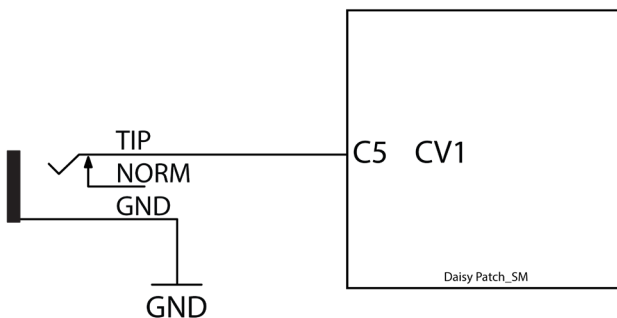

Input Impedance: 100K

Available Pins:

CV_1 to CV_8

Example Parts:

[Thonkiconn 3.5mm Mono Eurorack Jack](#)

MPN: WQP-WQP518MA



Typical Applications

Figure 1.4 - Gate Input application example

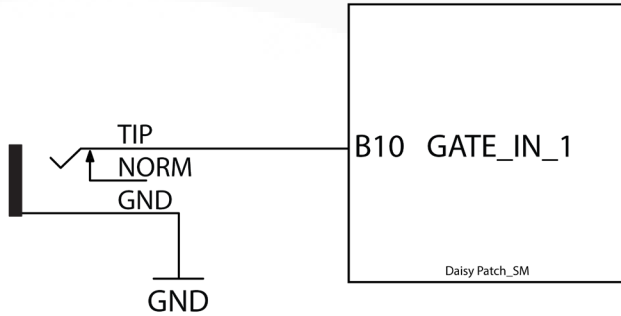

Input Impedence: 100K

Available Pins:
GATE_IN_1, GATE_IN_2
CV_1 to CV_8*

Example Parts:
[Thonkiconn 3.5mm Mono Eurorack Jack](#)
MPN: WQP-WQP518MA

* When using CV pins for gate signals, the signal will be read in as an analog value

Figure 1.5 - Tactile Switch application example

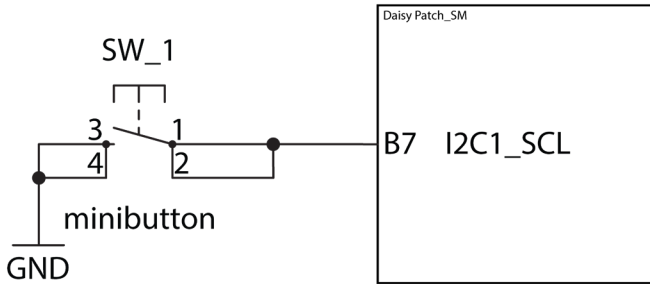

Available Pins: Any GPIO

Example Parts:
[Tactile Switch](#)
MPN: TL1105SPF250Q

Figure 1.6 - Toggle Switch application example

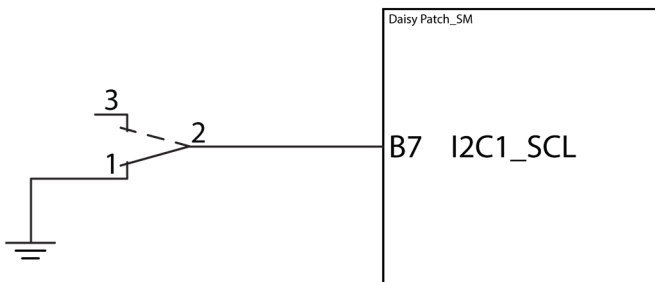

Available Pins: Any GPIO

Example Parts:
[Toggle Switch](#)
MPN: 2MS1T1B1M2QES



Typical Applications

Figure 1.7 - Micro SD application example

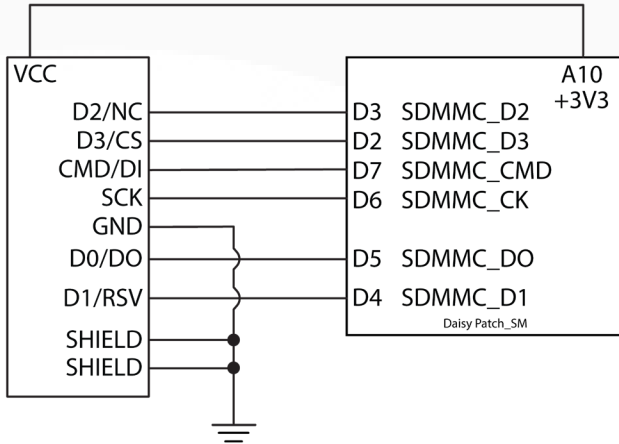

No pullup resistors necessary.

Example Parts:

[Vertical MicroSD Card Connector](#)

MPN: PJS008U-3000-0

Figure 1.8 - Stereo Audio Output application example

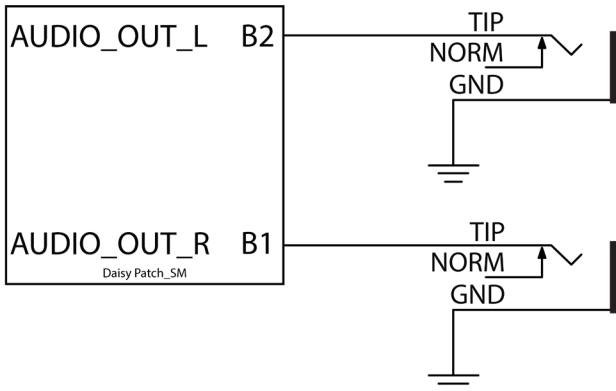

Output Impedence: 100R

Example Parts:

[Thonkiconn 3.5mm Mono Eurorack Jack](#)

MPN: WQP-WQP518MA

Figure 1.9 - CV Output application example

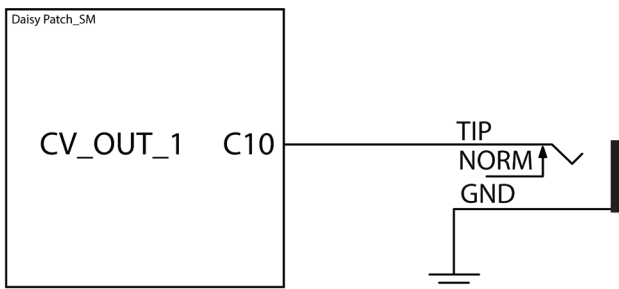

Output Impedence: 100R

Available Pins:

CV_OUT_1, CV_OUT_2

Example Parts:

[Thonkiconn 3.5mm Mono Eurorack Jack](#)

MPN: WQP-WQP518MA



Typical Applications

Figure 1.10 - Gate Output application example

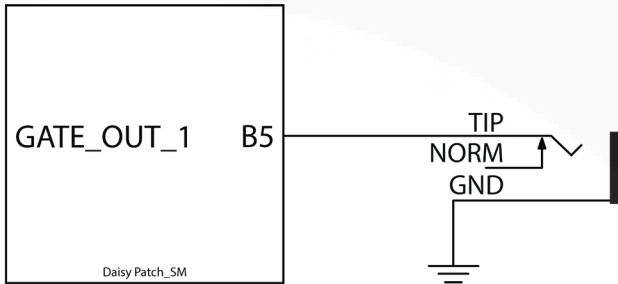

Output Impedance: 100R

Available Pins:
GATE_OUT_1, GATE_OUT_2
CV_OUT_1, CV_OUT_2*

Example Parts:
[Thonkiconn 3.5mm Mono Eurorack Jack](#)
MPN: WQP-WQP518MA

* Output signal will be an analog voltage

Figure 1.11 - Power application example

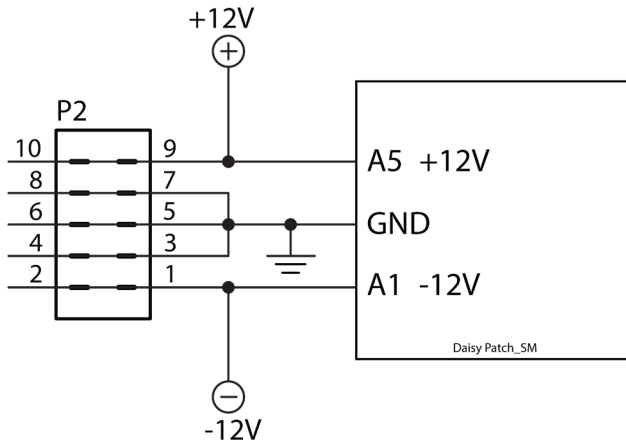

No bypass caps necessary.

Example Parts:
[2x5 Male PTH 2.54mm Vertical Header](#)

Figure 1.12 - LED application example

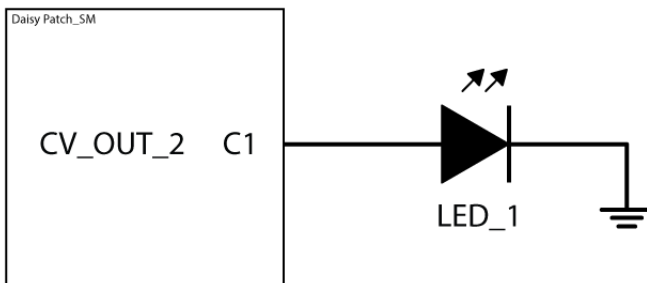

Output Impedance: 100R

Available Pins:
CV_OUT_1, CV_OUT_2
GATE_OUT_1, GATE_OUT_2
Any GPIO*

Example Parts:
[3mm LED](#)
MPN: WP132XND

* GPIO require an external resistor



Typical Applications

For electrical characteristics, see Table 2

Figure 1.13 - On-Off-On Toggle Switch

Available Pins: Any GPIO

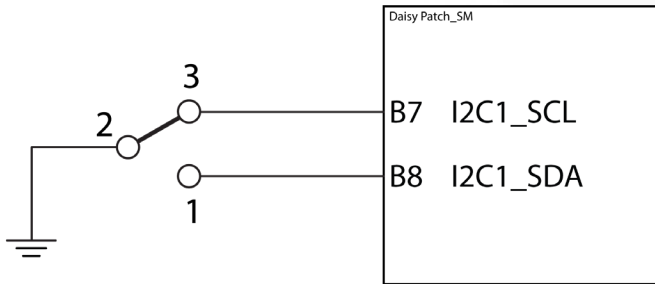

Example Parts:

[Toggle Switch](#)

MPN: TS-4A-TECQ-H



Technical Drawing

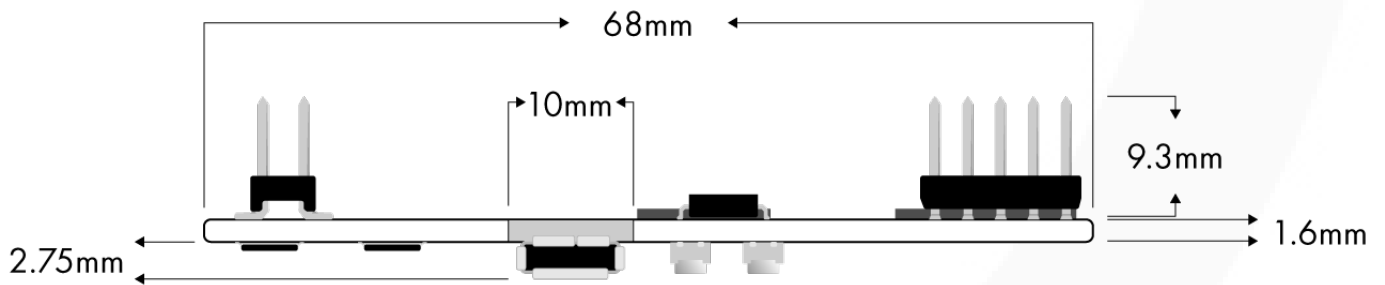
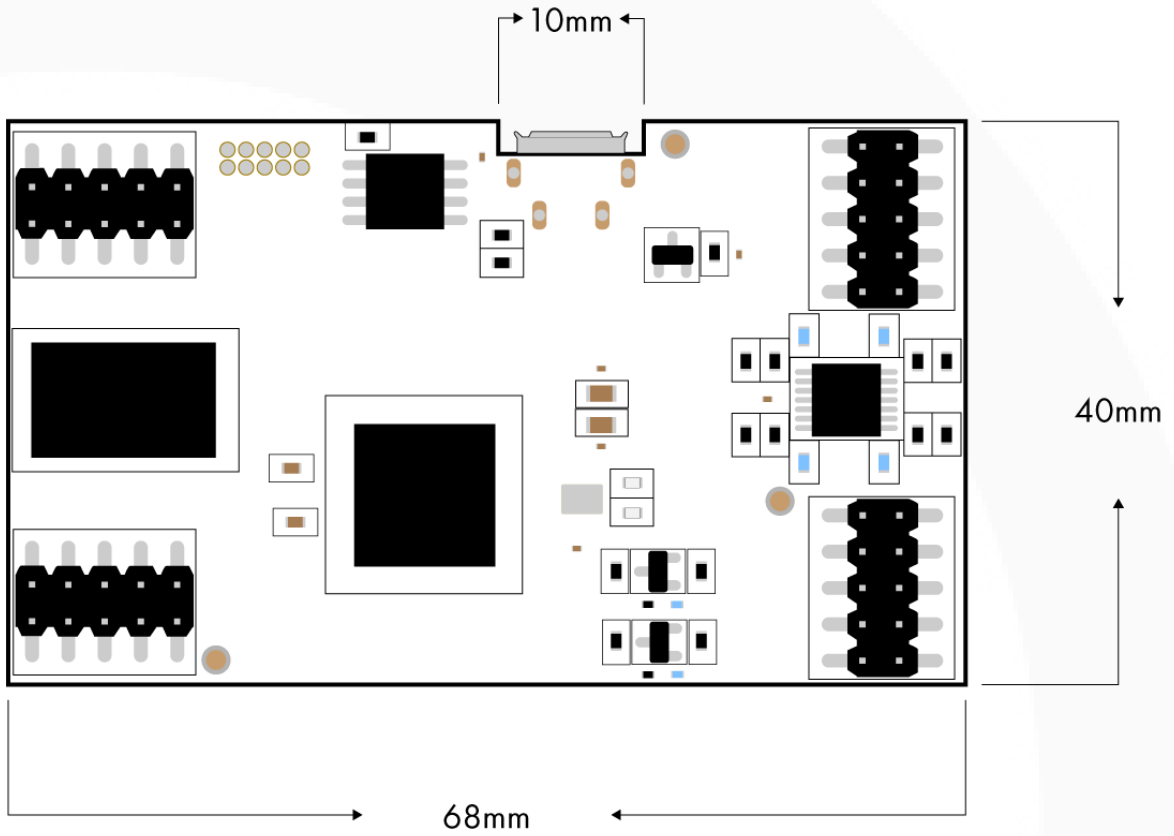



Landing Pattern

Dimensions in mm (inches)

Ø 1.016 (0.04)

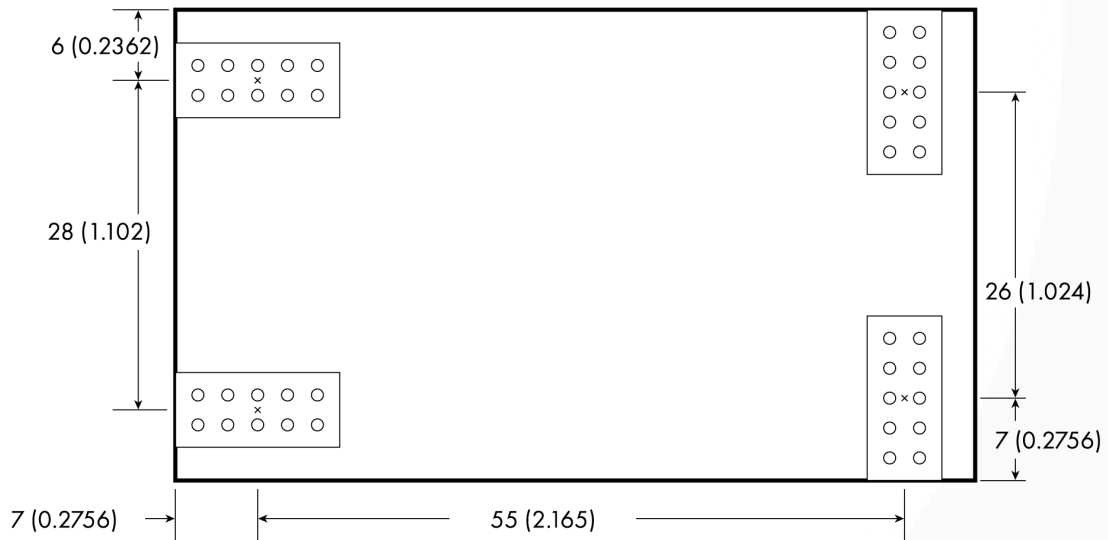
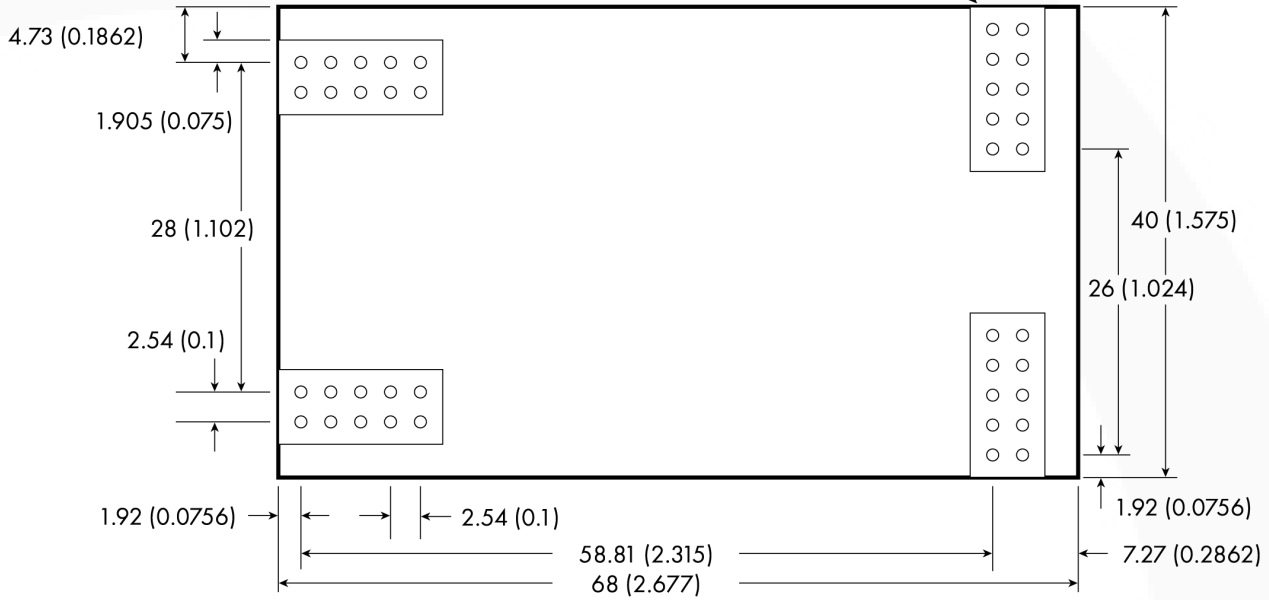



Why The Daisy Patch Submodule?

Made In The USA

The Daisy Seed is built by the Electrosmith team in San Clemente, CA. We take pride in knowing that each stage of our manufacturing process is handled in house so that we can provide the best quality, lead time, and pricing.

RoHS Compliant

Electrosmith manufacturing is 100% RoHS compliant. All Electrosmith products are free from RoHS defined hazardous materials.

CE/REACH Compliant

The Daisy Seed is assembled with parts and materials that are compliant with CE/REACH standards. Design with the Seed knowing that it upholds the highest environmental standards for electronic products.

FCC Class A Certification

The Daisy Patch Submodule is certified under the FCC Class A license. The associated paperwork is available for download on our website.





Changelog

RELEASE	DATE	DESCRIPTION
v1.0	1.1.22	<ul style="list-style-type: none">Initial release
v1.0.1	1.6.22	<ul style="list-style-type: none">added colophon, added pricing
v1.0.2	3.1.22	<ul style="list-style-type: none">Updated peripheral numbers in Pinout Table, update noise performance information
v1.0.3	3.15.22	<ul style="list-style-type: none">added On-Off-On Toggle Switch typical application
v1.0.4	5.23.22	<ul style="list-style-type: none">Updated STM32 pin name for pin D10
v1.0.5	25/JAN/2023	<ul style="list-style-type: none">Added power disclaimer to Absolute Maximum Ratings Table